

Your Need, Our Expertise

Crafting Solutions as Unique as You Are

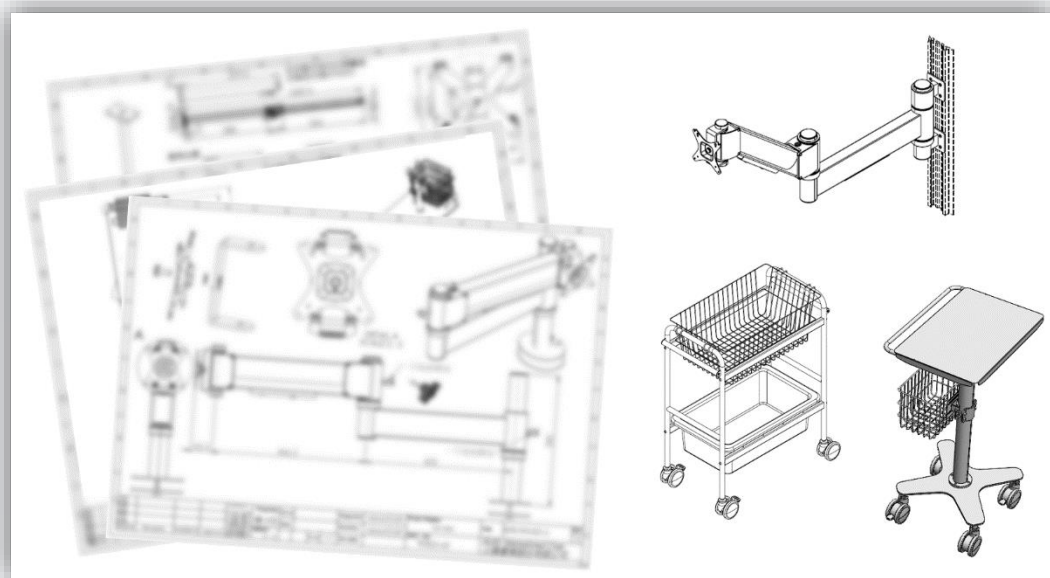

OEM/ODM/Components

CATALOG 2024

Kelly About

Kelly International Corp

Founded in 1965, Kelly is a renowned global manufacturer based in Taiwan and China. We specialize in producing ergonomic products spanning various sectors, including office workplaces, educational institutions, industrial settings, homes, and the healthcare industry. Since 2012, we've been dedicated to expanding our expertise in healthcare-related OEM projects, particularly with medical carts and mounts.

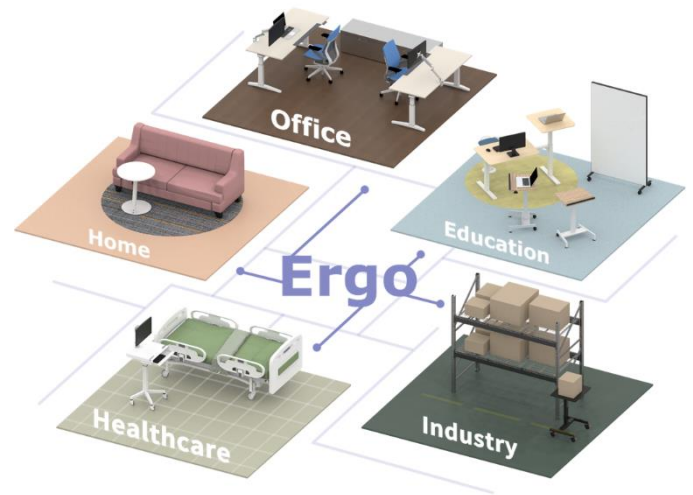

Customer Orientation

We, at Kelly, are committed to satisfy the customers' needs. By working in partnership with our worldwide customers, Kelly is proactively solving their problems through our years OEM/ODM experience, superior product quality, flexibility and competitive price, thereby achieving customer expectation and success.

Kelly Quality Management

We are proud to be ISO 9001 certified. These certifications demonstrate Kelly's commitment to enhanced quality of service, Continually improvement, increased employee and company efficiency, and unparalleled responsibility.

IQC

- Material confirmation
- Material strength inspection
- Dimension measurement
- Color control
- Reliability check

OQC

- Check all cartons well packed
- Professional goods loading
- Photo record for every shipment



IPQC

- Detailed SOP in assembly process
- Exclusive-designed gauge
- First article inspection
- Check point setup

FQC

- Full inspection for crucial function
- AQL final inspection
- Complete inspection report record

Honesty

Kelly Customization Capability

Consultation for Cost-Effective Solutions

Transparent & Rapid Communication

Flexible Manufacturing

Quality Assurance & Timely Delivery

Kelly Custom & OEM Solutions



New Project Initiation

- Provide in-depth project discussion
- Early engineering involvement
- Provide best time schedule and quotation

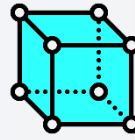

Tooling Process

- Expert in tooling design to prolong the tooling lifetime
- Make best tooling precision



Prototype Test

- Quick prototyping
- Perform prototype reliability test



Manufacturing

- Batch manufacturing at our certified quality factory
- Production assembly



Quality control & Assurance

- IQC oncoming materials inspection & quality control
- In house inspection instrument to ensure product quality

Kelly, Your Best Partner in Product Development



- Over 20 years of resources and expertise in ergonomic OEM/ODM solutions
- One station service for integration in various materials
- Dedicated team for every **ODM/OEM** Project
- Prompt communications and quick reactions for every discussion
- Professional production suggestions for your products
- Quick and flexible manufacturing
- Knowledgeable with field applications

Kelly Capability



Metal Processing



Plastic Processing



Integration



Assembly Capability

Metal Processing

- Sheet Metal
- Square Tube
- Round Tube
- Rectangular tube
- Oval tube

Thickness: 0.6 ~ 10mm



Aluminum Die-casting

- Support production with various sizes (die-casting machine from 125T to 800T)
- Product size: Max. 50 x 50 cm, 4.5 KG

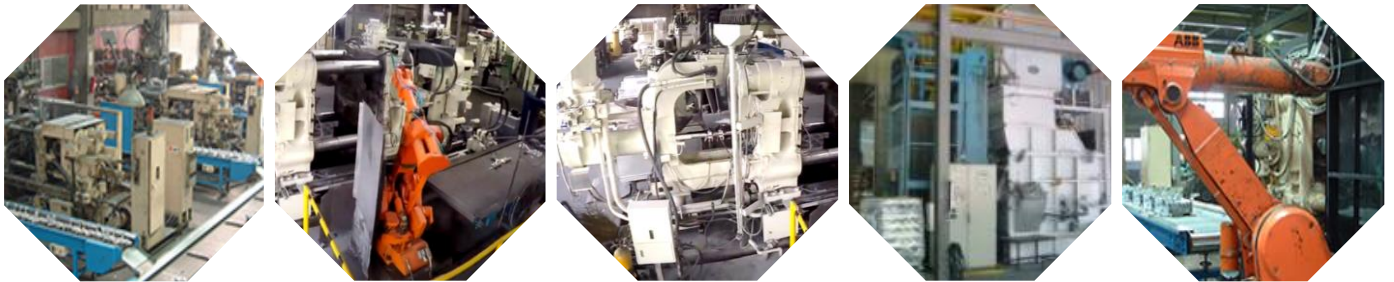

Aluminum Extrusion

- Support production with various sizes, extrusion machine: 660 to 2500 ton



Plastic Processing

Material: ABS, HIPS, PP, etc.

Injection Method:

- Over-molding Injection
- Double Injection
(Different material & two tone)
- Two shot Molding
(Same Material Two Tone)

Injection machine: 80 to 1100 ton,
support product weight range from 0.5g-5000g



Surface Finish

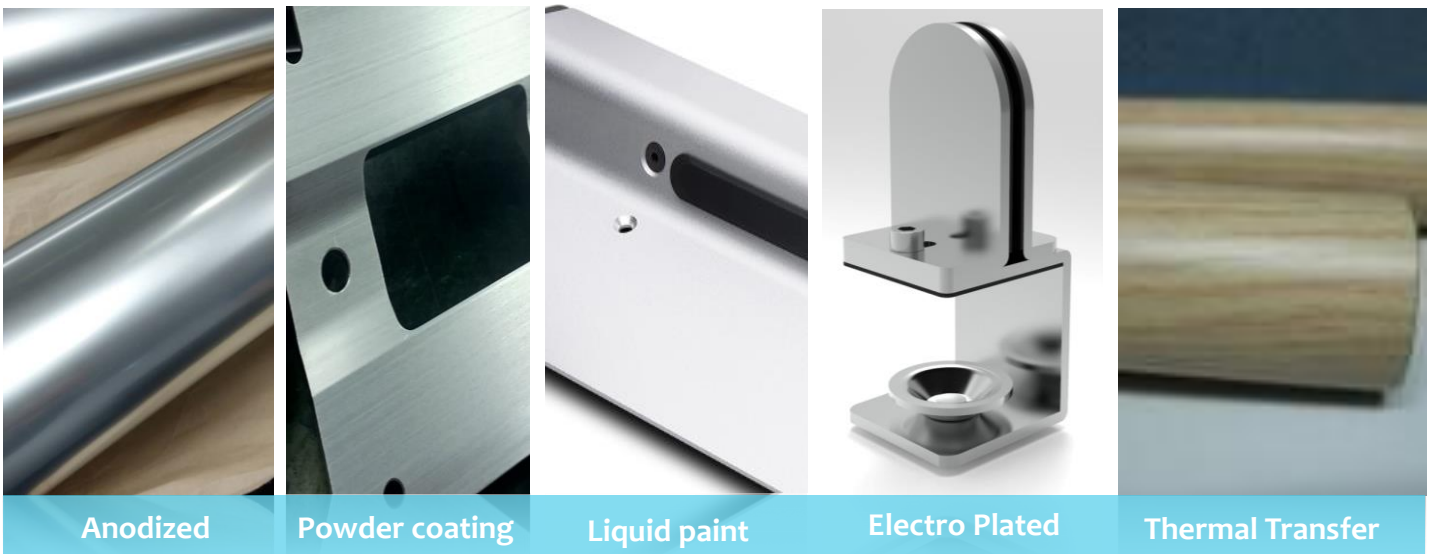

Anodized

Powder coating

Liquid paint

Electro Plated

Thermal Transfer

Integration

- Component integration like motor, battery, charger, gas spring, etc.
- Solution integration like camera, computer etc.



Assembly Capability

- We provide assembly solutions, design exclusive fixture/gauge for assembly work and create the appropriate packaging.
- Standardized workflows and up-to-date documentation ensure consistently high quality.





Base

X base Ø400	X base Ø550	H base	M base	Aluminum base

Column

Fixed pole Ø38.1 Customized height	pole Ø50.8 + Ø38.1 Height adjustment (quick release)	Square tube 60x60 + 50x50 Height adjustment (hand or foot paddle)

Caster & Bumper

Caster A	Caster S	Caster H	Caster D	Bumper

Heavy Duty Arm

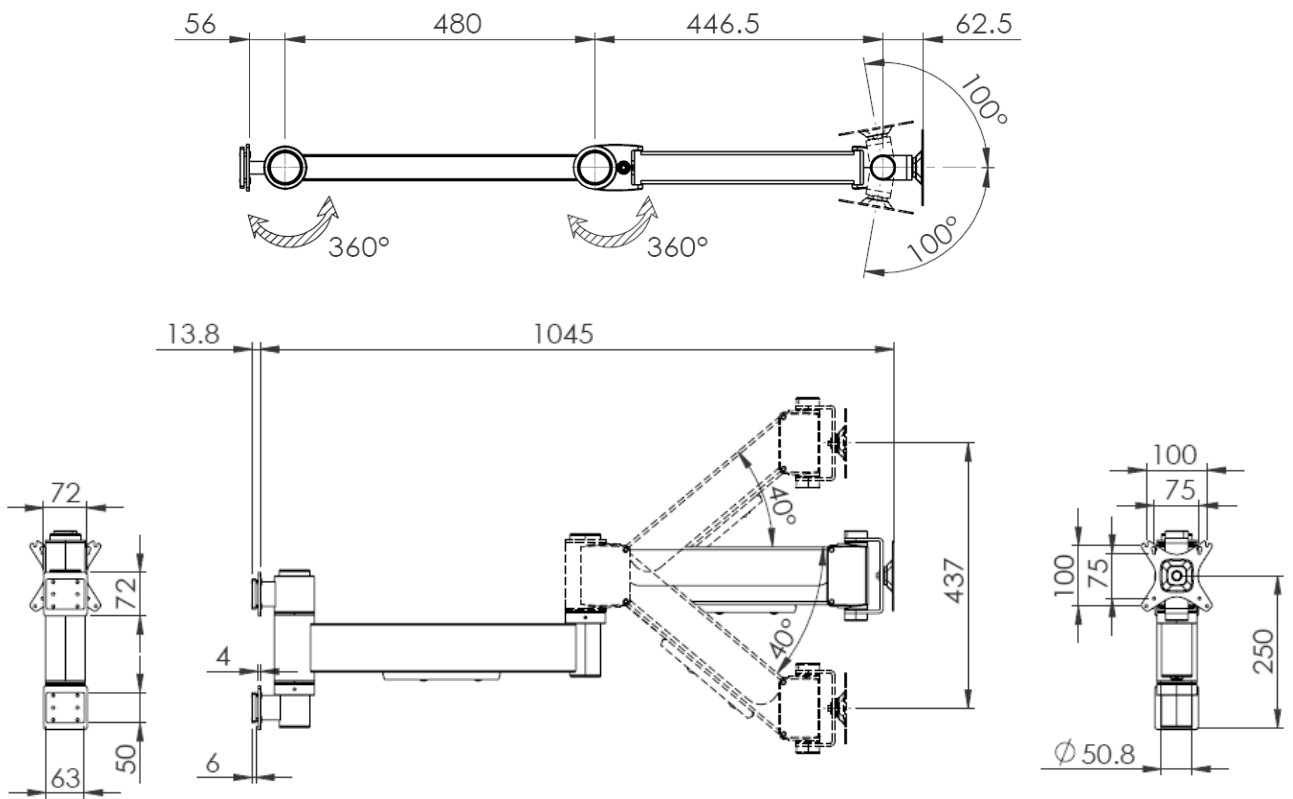
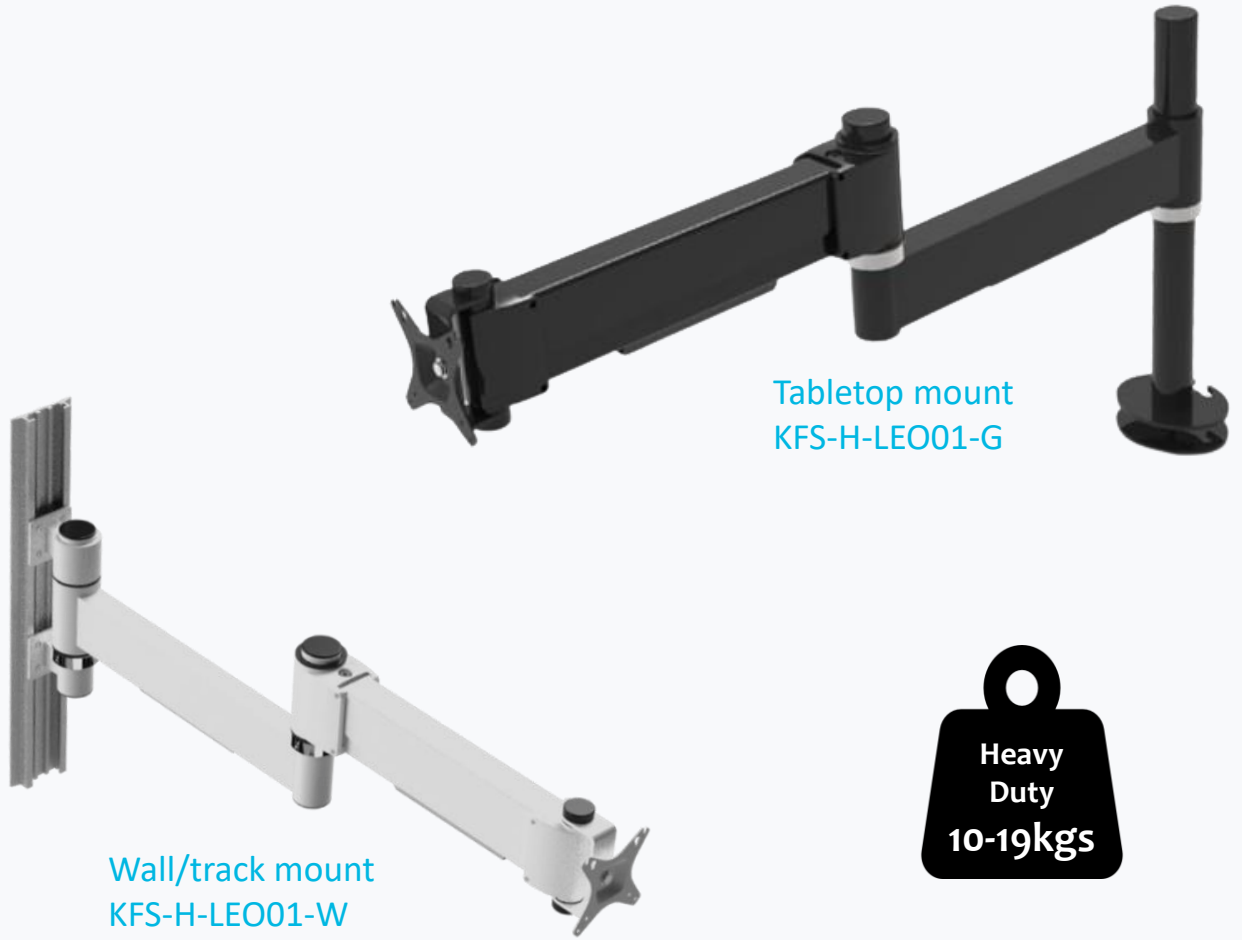

KFS-H-M2301-W Single Monitor

Support wall/track mount
Loading 2-12kgs
Monitor size up to 42"

KFS-H-M2301-W-2 Dual Monitor

Support wall/track mount
Loading 2-11kgs
Monitor size 2x29" in landscape view
or 1x34 in landscape view + 1x29" in
portrait view



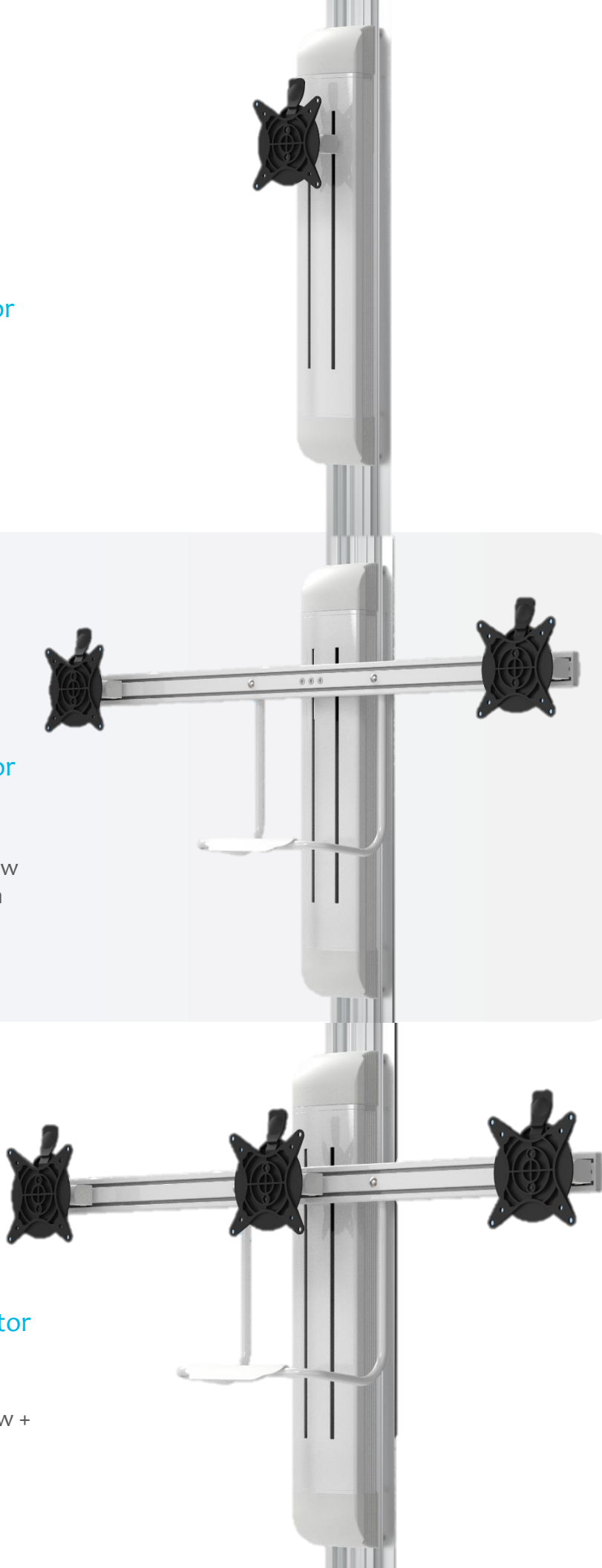

KFS-H-M2301-W-3 Triple monitor

Support wall/track mount
Loading 2-11kgs
Monitor size 1x19" in landscape view +
2x19" in portrait view





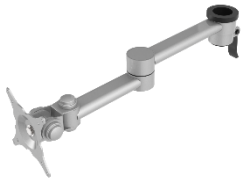
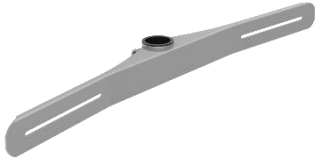



Arm

		
Single arm	Single swing arm – A type	Single swing arm – B type
		
Cross bar	Dual swing arm	Extra wide dual swing arm

Fixture







			
Rotatable quick release fixture	Non-rotatable quick release fixture	Clamp (for pole width 38~50 mm)	Basic pole clamp



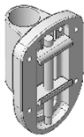
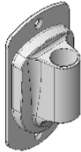

Arm

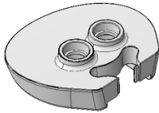
		
Gas spring arm	Long extension arm	Short extension arm

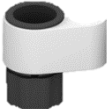
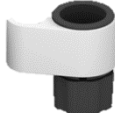
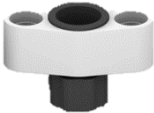
Mount

				
Slate wall bracket	Wall mount bracket	Table through ≤ 2.0" (50mm)	Desk clamp ≤ 1.7" (43mm)	Above desk mount
				
Dual mount base	Pole mount	Single support-holder	Add-on single support-holder	Dual support-holder

Bracket

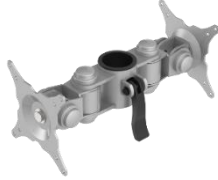
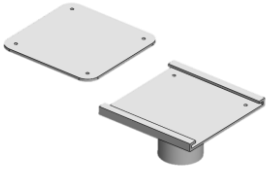
			
Sing-U VESA head Pan & rotation function	Double U VESA head Pan & tilt & rotation function	Back to back bracket Pan & tilt & rotation function	Equipment bracket Customizable based on your needs

Mesh basket

		
KF-H-O2301 Large mesh basket 300x200x145mm	KF-H-O2302 Small mesh basket 240x150x160mm	KF-H-O2306 Large mesh basket with hooks 330x200x200mm

More

				
Tablet holder iPAD 9.7"	Tablet holder iPAD 10.2" & 10.5"	Laptop security bar	Cable management	CPU holder
				
Table top	Portable battery	Hot swap battery	Handle	Cable clip
				
Counterweights	Laptop tray	Probe holder		